

- NOTES:
1. ALL DIMENSIONS ARE IN INCHES.
 2. ALL TOLERANCES SHALL BE ± 0.05 .
 3. THIS DRAWING IS THE PROPERTY OF THE CLOROX COMPANY.
 4. MATERIAL SHALL BE 3D PRINTED PLA.



BASE PLATE A

DR. BY: R. M. FOSTER

SHEET NO.

DATE: 4/24/2021

SCALE: 1:2

1
OF 2

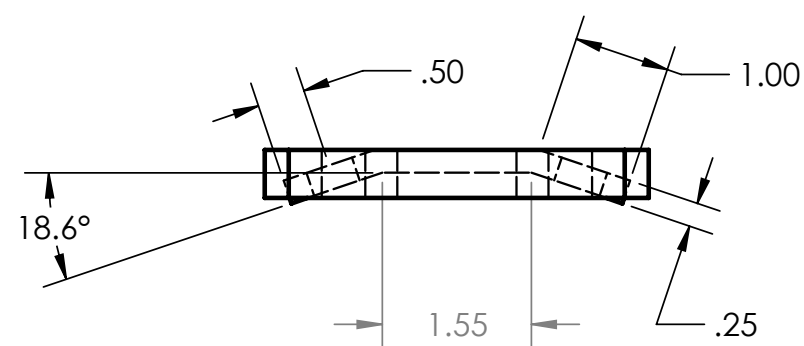
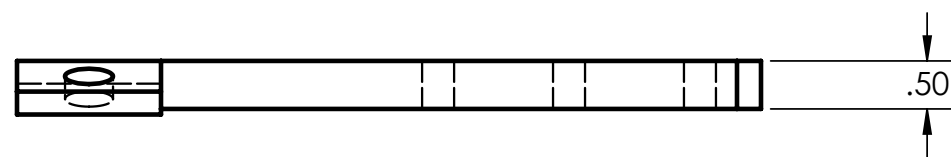
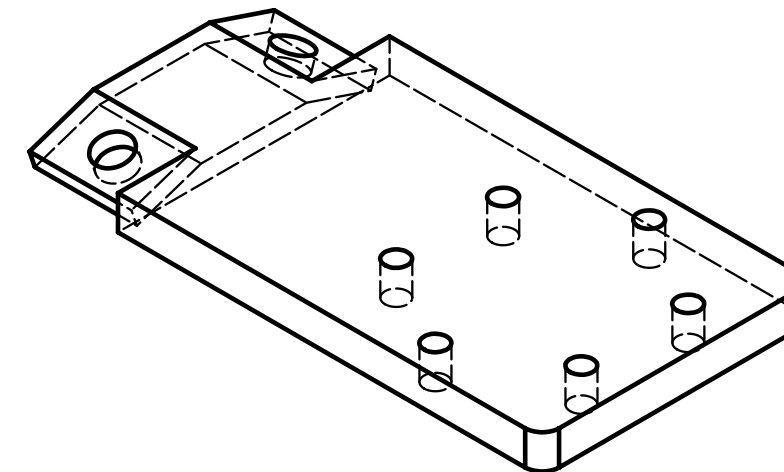
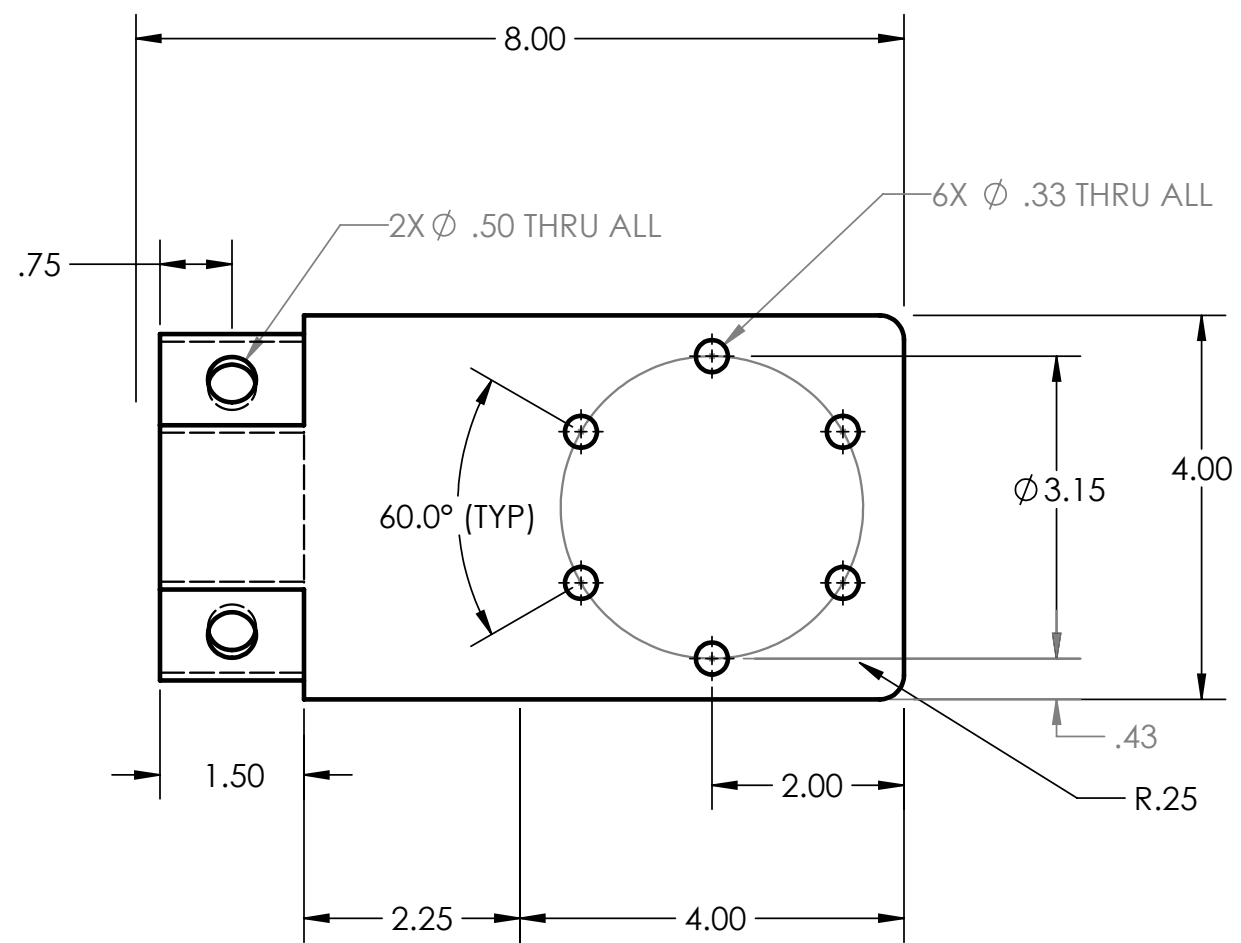

NOTES:

1. ALL DIMENSIONS ARE IN INCHES.
2. ALL TOLERANCES SHALL BE ± 0.05 .
3. THIS DRAWING IS THE PROPERTY OF THE CLOROX COMPANY.
4. MATERIAL SHALL BE 3D PRINTED PLA.



BASE PLATE B

DR. BY: R. M. FOSTER

SHEET NO.

DATE: 4/24/2021

SCALE: 1:2

2
OF 2

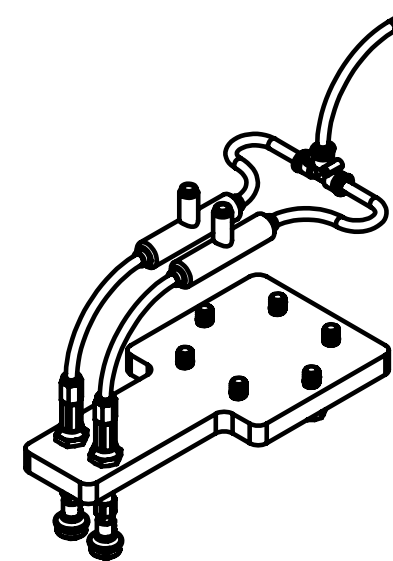
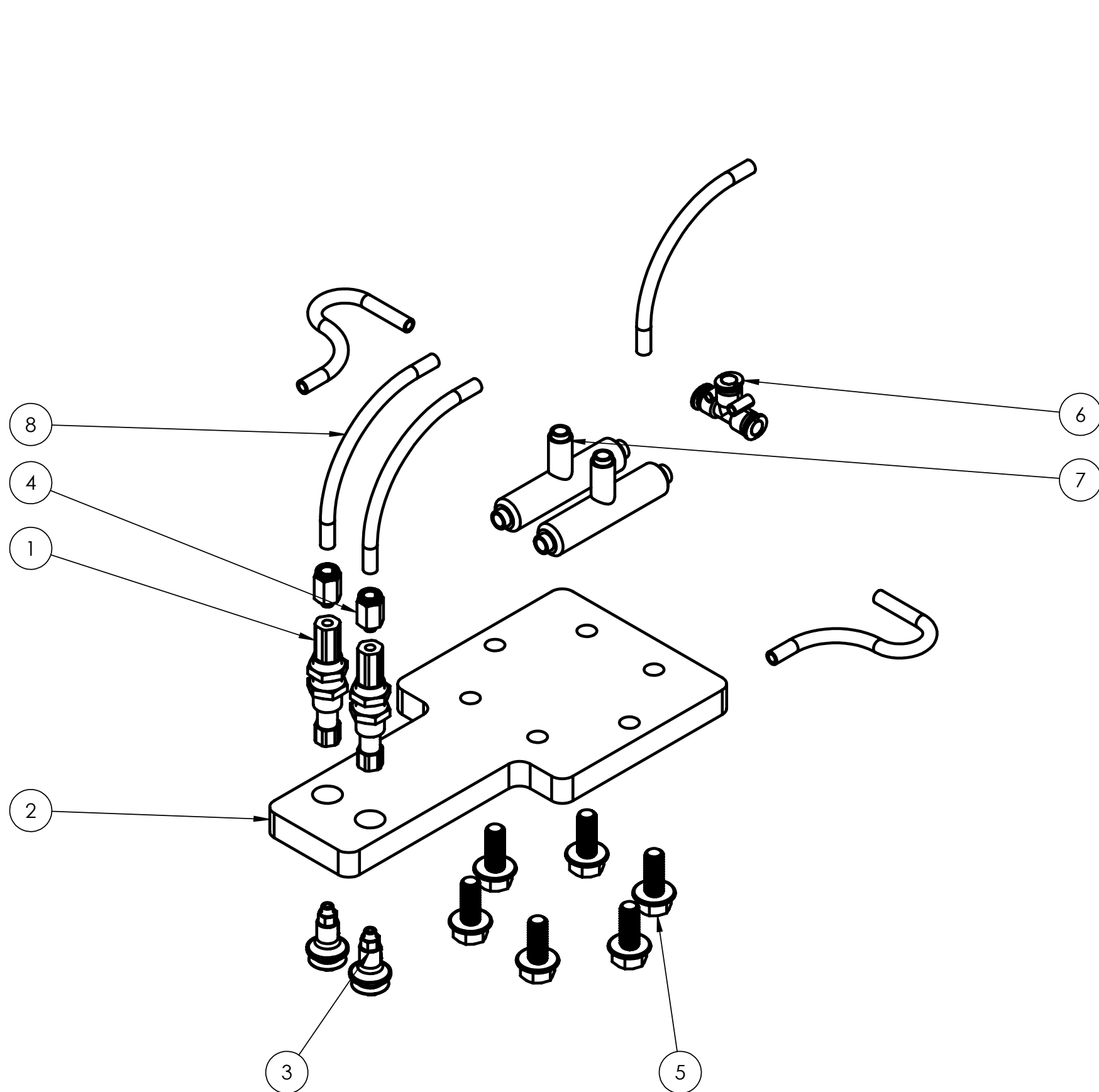

NOTES:

- THIS DRAWING IS THE PROPERTY OF THE CLOROX COMPANY.

ITEM NO.	PART NAME	QTY
1	LEVEL COMPENSATOR	2
2	BASE PLATE A	1
3	B15-2 SUCTION CUP	2
4	TUBING CONNECTOR	2
5	M8 BOLT	6
6	T-JOINT	1
7	I-MPVG-T85H VACUUM PUMP	2
8	TUBING (PROVIDE 8 BAR PRESSURE)	3



BASE PLATE A EXPLODED

DR. BY: R. M. FOSTER

SHEET NO.

DATE: 4/24/2021

SCALE: 1:2

1
OF 2

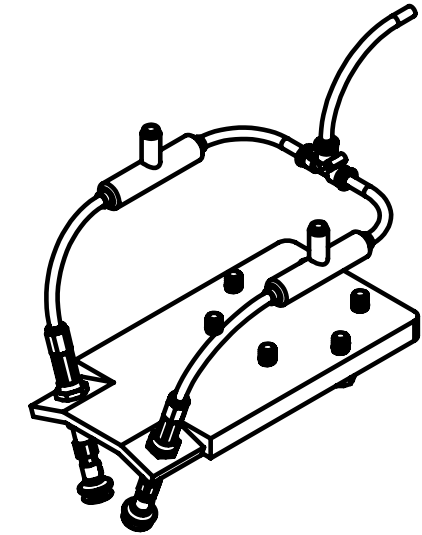
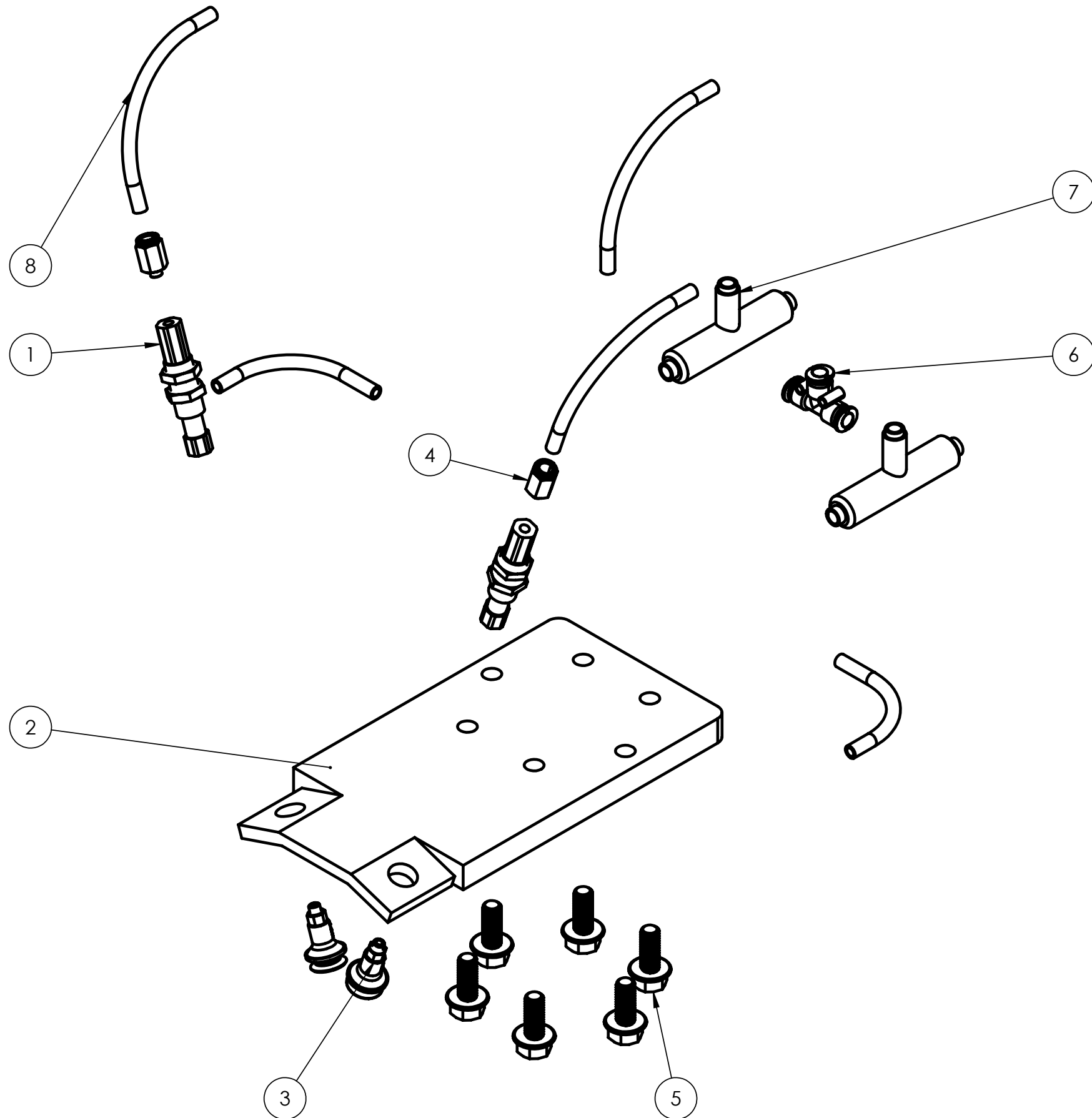

NOTES:

- THIS DRAWING IS THE PROPERTY OF THE CLOROX COMPANY.

ITEM NO.	PART NAME	QTY
1	LEVEL COMPENSATOR	2
2	BASE PLATE B	1
3	B15-2 SUCTION CUP	2
4	TUBING CONNECTOR	2
5	M8 BOLT	6
6	T-JOINT	1
7	I-MPVG-T85H VACUUM PUMP	2
8	TUBING (PROVIDE 8 BAR PRESSURE)	3



BASE PLATE B EXPLODED

DR. BY: R. M. FOSTER

SHEET NO.

DATE: 4/24/2021

SCALE: 1:2

2
OF 2

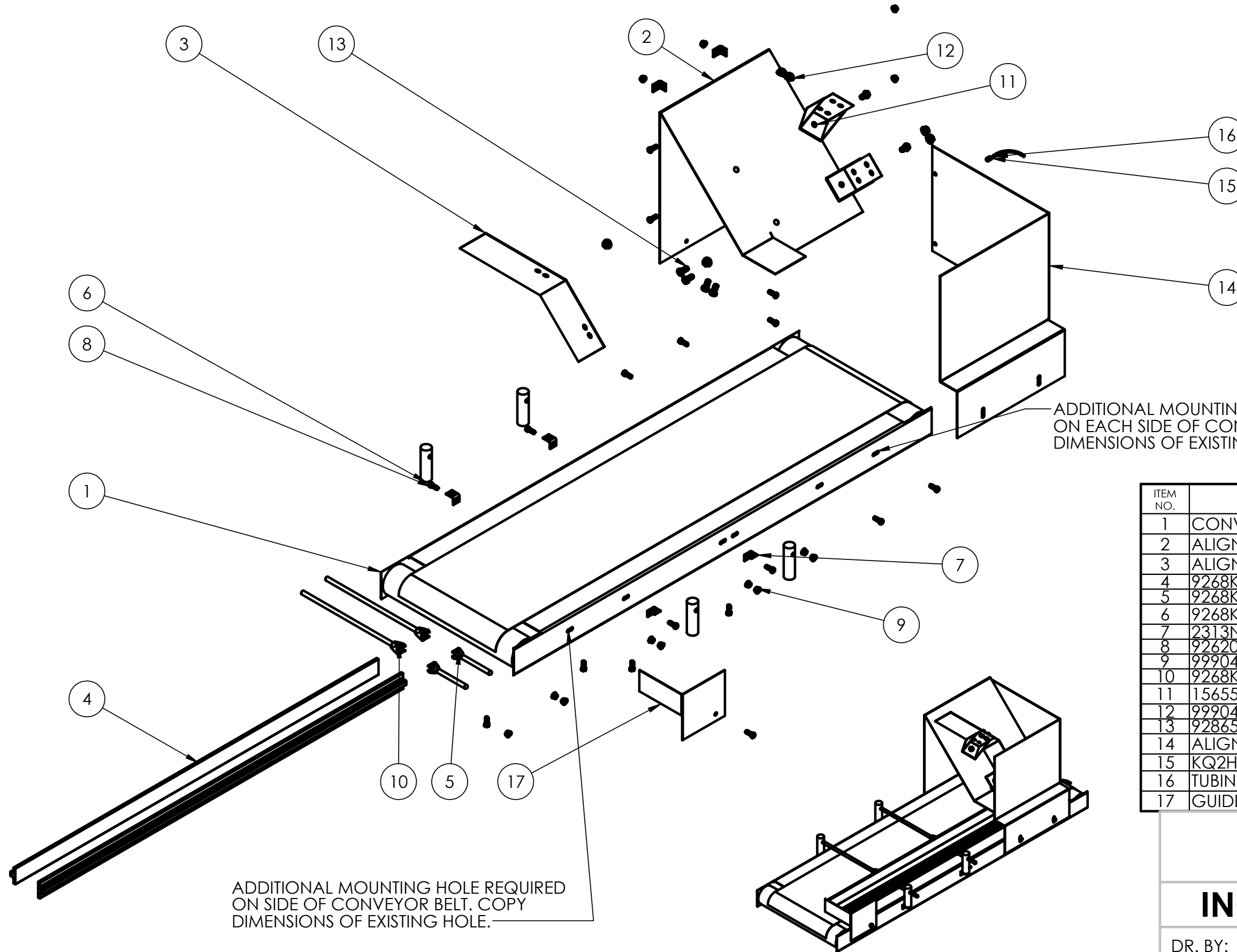

- NOTES:
1. ALL DIMENSIONS ARE IN INCHES.
 2. ALL TOLERANCES SHALL BE ± 0.05 .
 3. THIS DRAWING IS THE PROPERTY OF THE CLOROX COMPANY.
 4. SPACING BETWEEN CONVEYOR GUIDES SHALL BE 4.00 WHILE IN 24 OZ BOTTLE MODE AND 4.25 WHILE IN 43 OZ BOTTLE MODE.

ADDITIONAL MOUNTING HOLE REQUIRED ON EACH SIDE OF CONVEYOR BELT. COPY DIMENSIONS OF EXISTING HOLE.

ADDITIONAL MOUNTING HOLE REQUIRED ON SIDE OF CONVEYOR BELT. COPY DIMENSIONS OF EXISTING HOLE.

ITEM NO.	PART NAME	QTY
1	CONVEYOR BELT	1
2	ALIGNMENT RAMP	1
3	ALIGNMENT FUNNEL	1
4	9268K128	2
5	9268K311	2
6	9268K67	4
7	2313N23	6
8	92620A624	13
9	99904A103	13
10	9268K317	2
11	15655A290	2
12	99904A104	6
13	92865A712	6
14	ALIGNMENT GUARD	1
15	KQ2H06-M5A	1
16	TUBING (PROVIDE 4.5 BAR PRESSURE)	1
17	GUIDE STOP	1



INCOMING ALIGN. SYS.

DR. BY: R. M. FOSTER

SHEET NO.

DATE: 4/24/2021

SCALE: 1:12

1
OF 1

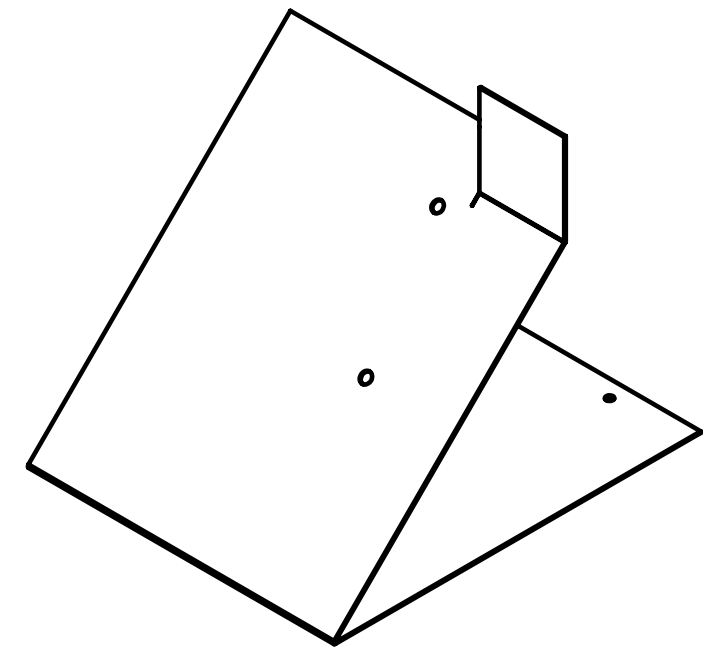
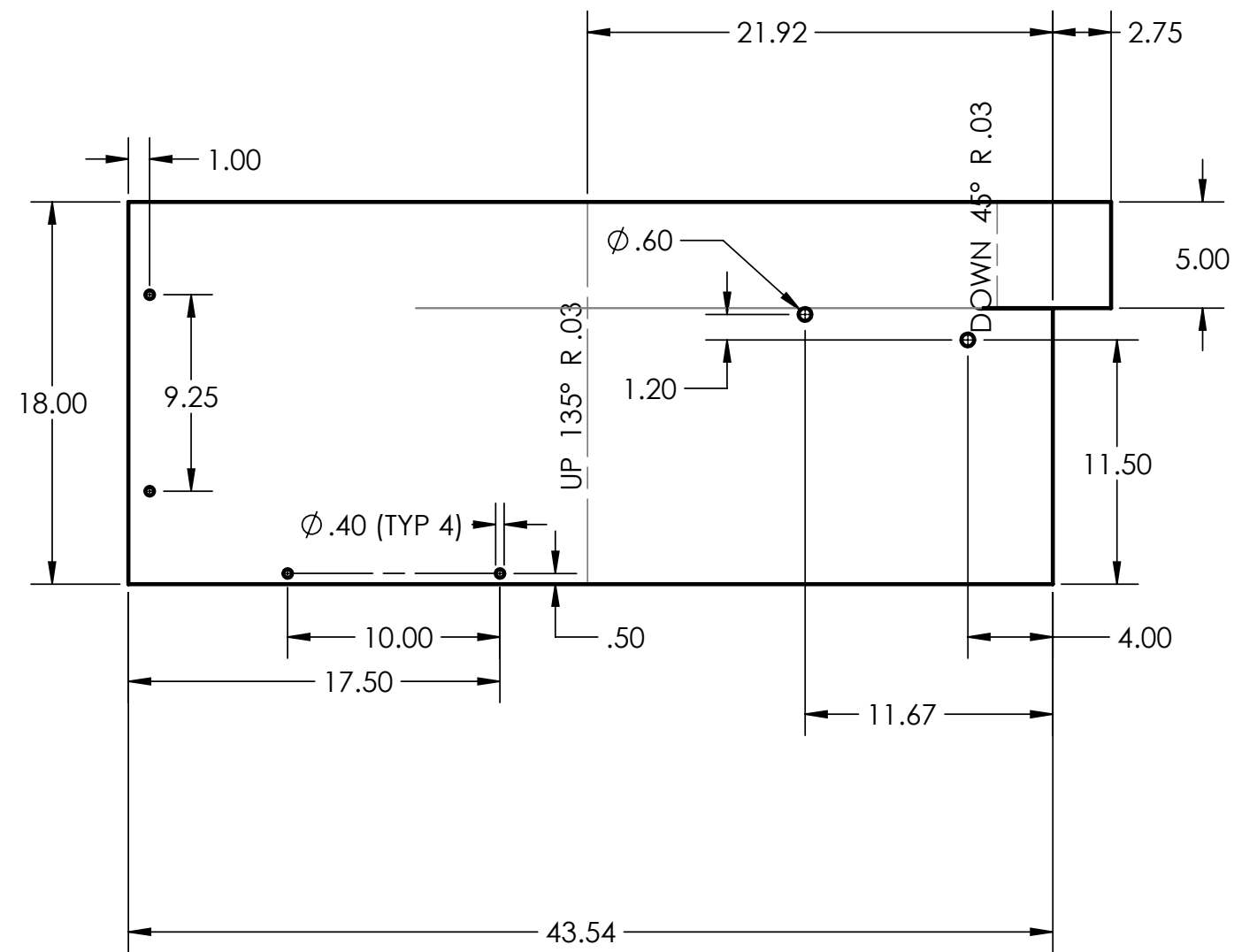

NOTES:

1. MATERIAL SHALL BE 11 GAUGE LOW CARBON STEEL SHEET METAL.
2. ALL DIMENSIONS ARE IN INCHES.
3. ALL TOLERANCES SHALL BE ± 0.01 .
4. THIS DRAWING IS THE PROPERTY OF THE CLOROX COMPANY.



ALIGNMENT RAMP

DR. BY: R. M. FOSTER

SHEET NO.

DATE: 4/24/2021

SCALE: 1:8

1
OF 1

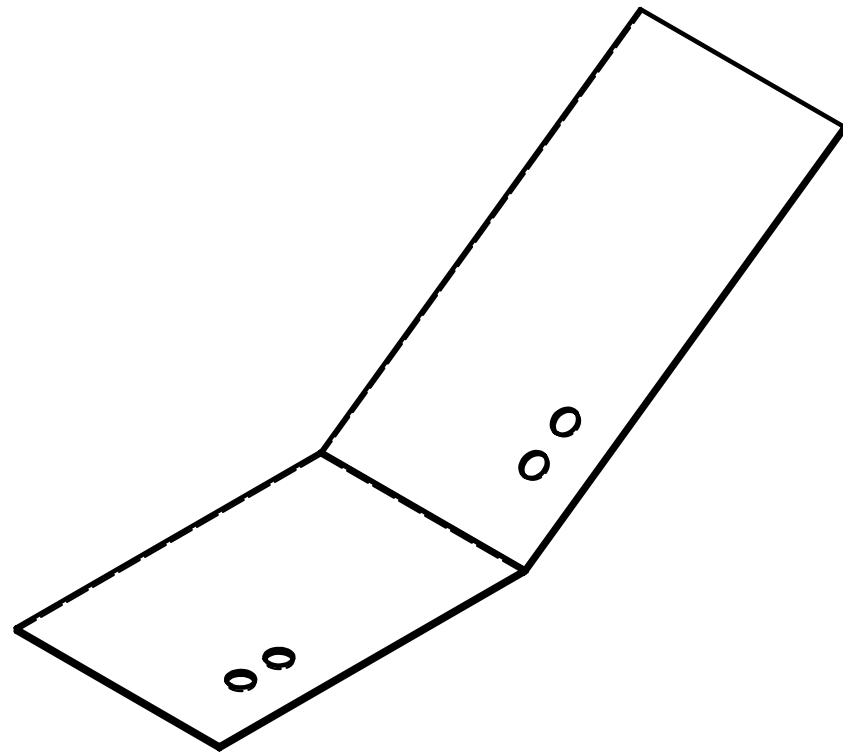

NOTES:

1. MATERIAL SHALL BE 11 GAUGE LOW CARBON STEEL SHEET METAL.
2. ALL DIMENSIONS ARE IN INCHES.
3. ALL TOLERANCES SHALL BE ± 0.01 .
4. THIS DRAWING IS THE PROPERTY OF THE CLOROX COMPANY.

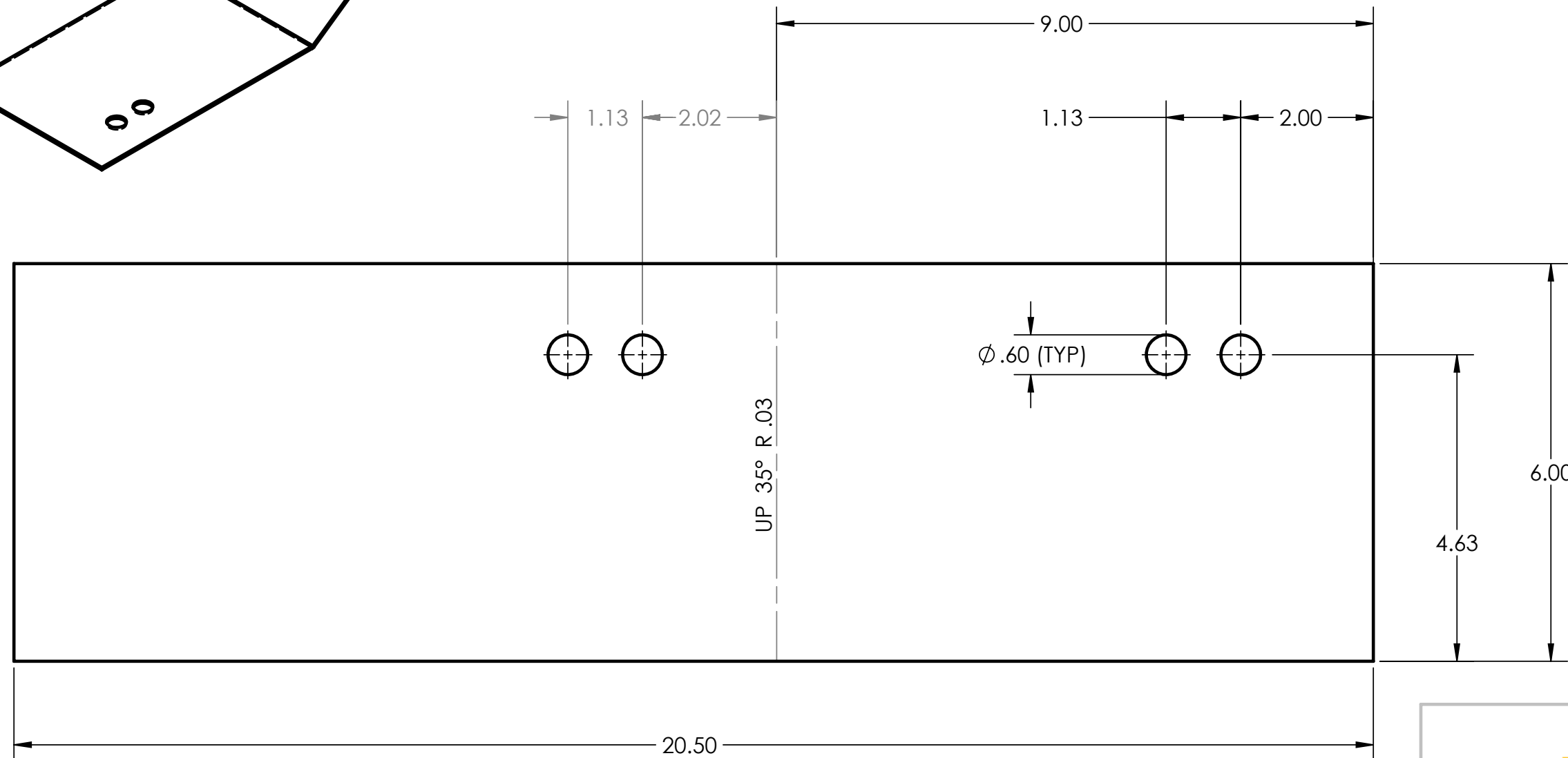

ALIGNMENT FUNNEL

DR. BY: R. M. FOSTER

SHEET NO.

DATE: 4/24/2021

SCALE: 1:2

1
OF 1

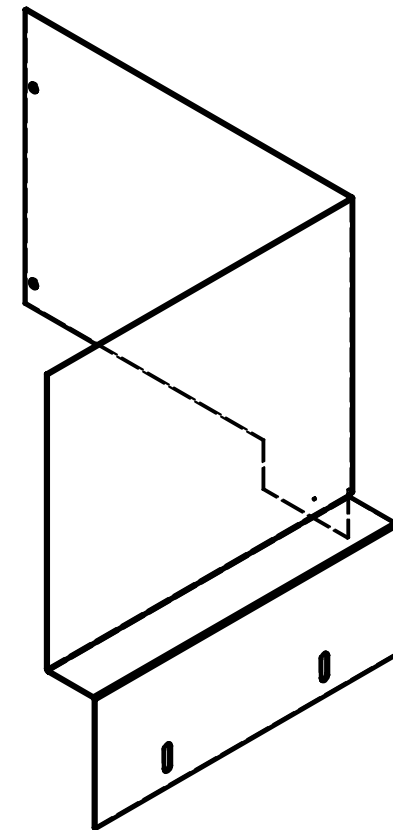
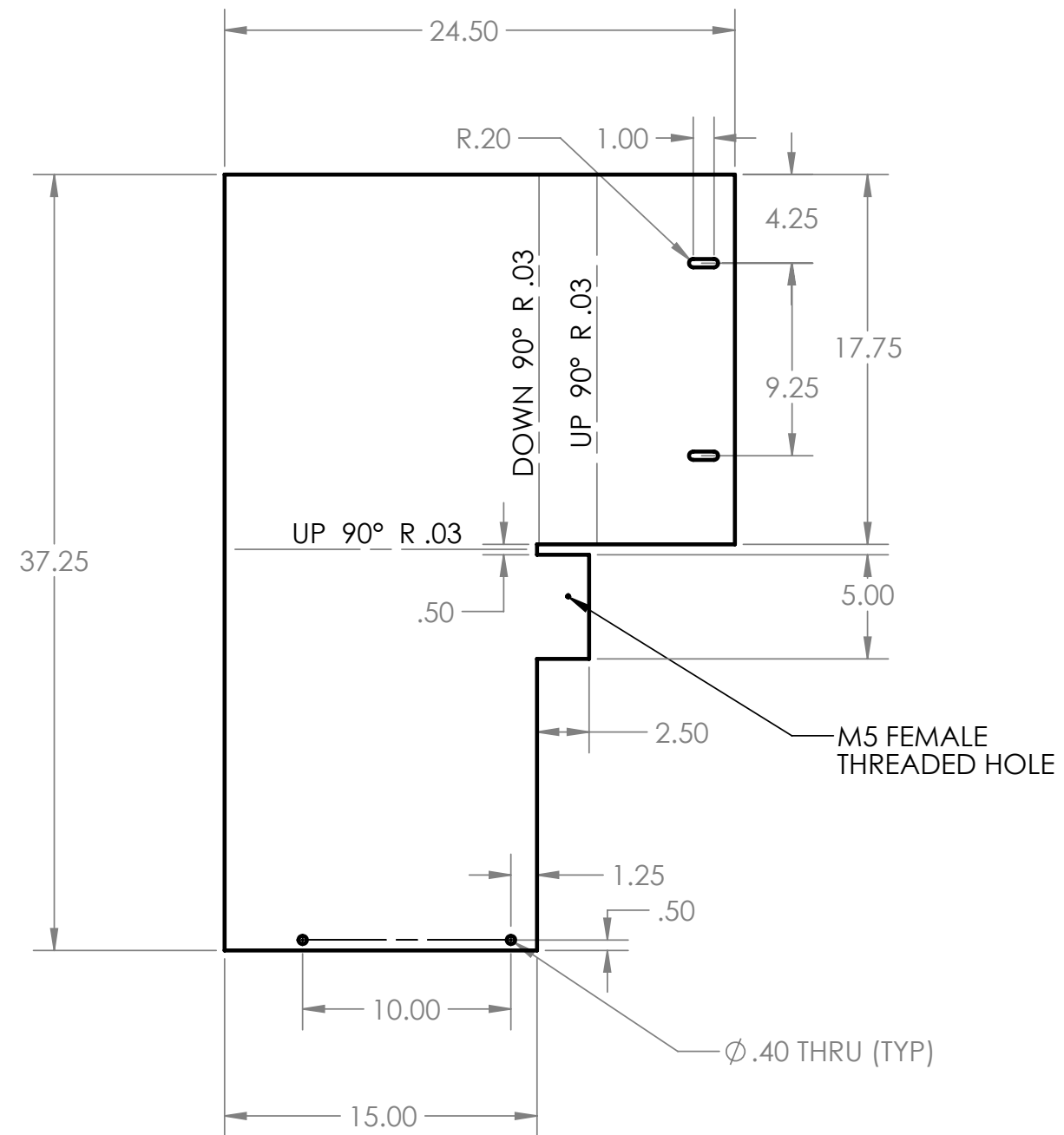

NOTES:

1. MATERIAL SHALL BE 11 GAUGE LOW CARBON STEEL SHEET METAL.
2. ALL DIMENSIONS ARE IN INCHES.
3. ALL TOLERANCES SHALL BE ± 0.01 .
4. THIS DRAWING IS THE PROPERTY OF THE CLOROX COMPANY.



ALIGNMENT GUARD

DR. BY: R. M. FOSTER

SHEET NO.

DATE: 4/24/2021

SCALE: 1:8

1
OF 1

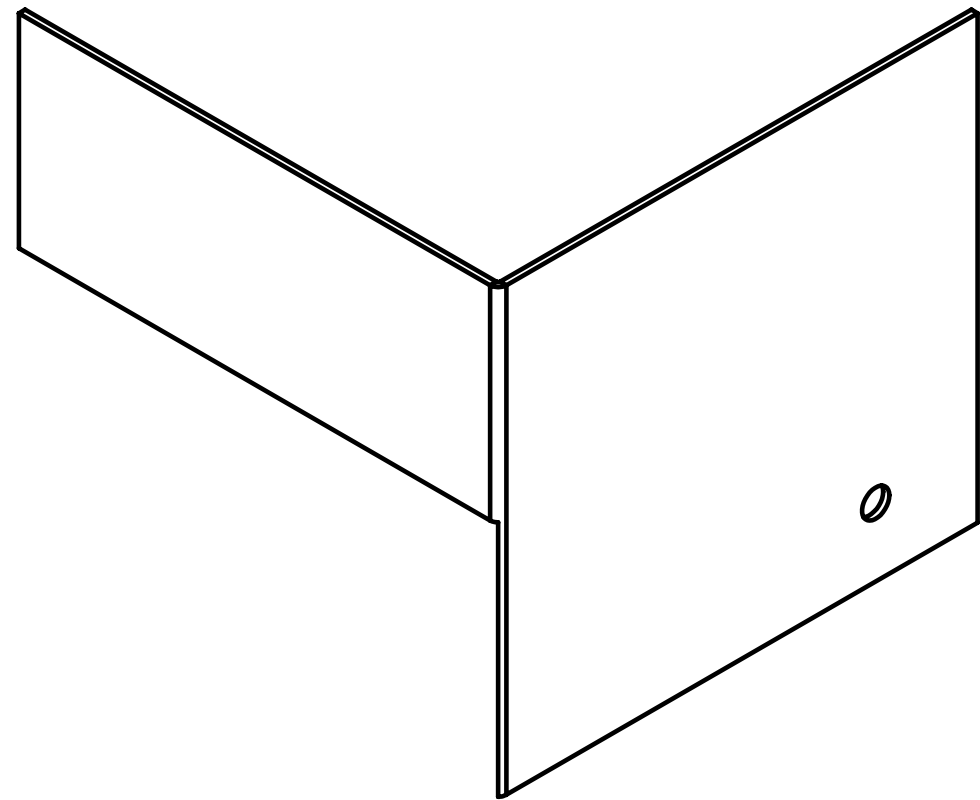
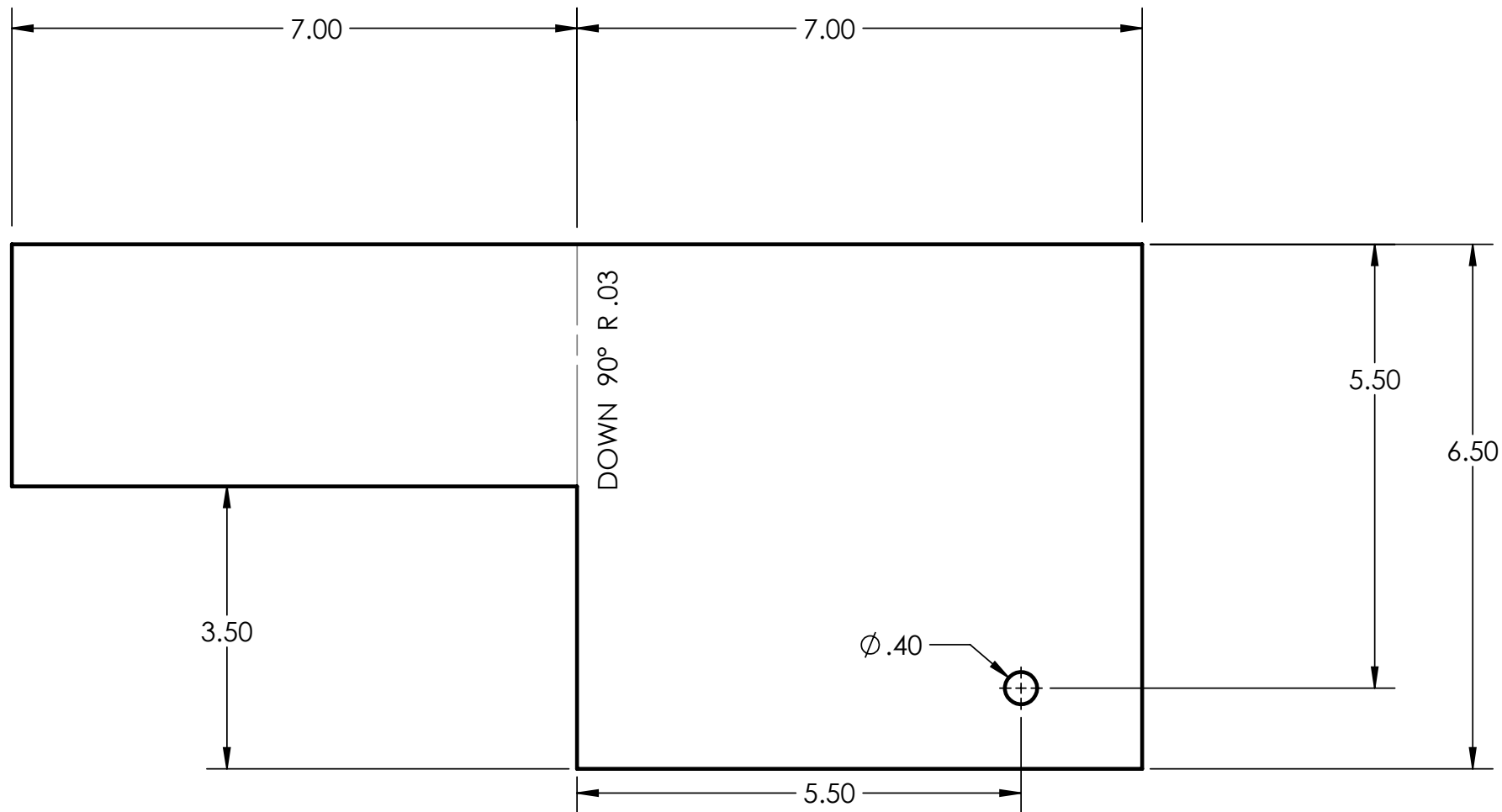

NOTES:

1. MATERIAL SHALL BE 11 GAUGE LOW CARBON STEEL SHEET METAL.
2. ALL DIMENSIONS ARE IN INCHES.
3. ALL TOLERANCES SHALL BE ± 0.01 .
4. THIS DRAWING IS THE PROPERTY OF THE CLOROX COMPANY.



GUIDE STOP

DR. BY: R. M. FOSTER

SHEET NO.

DATE: 4/24/2021

SCALE: 1:2

1
OF 1

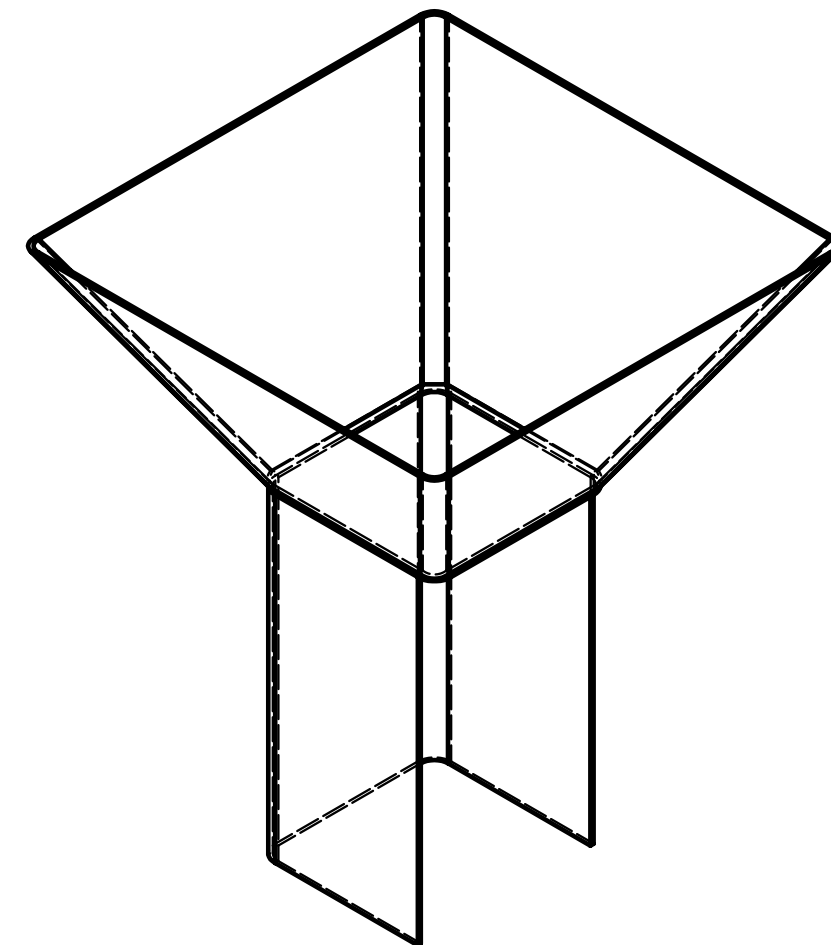
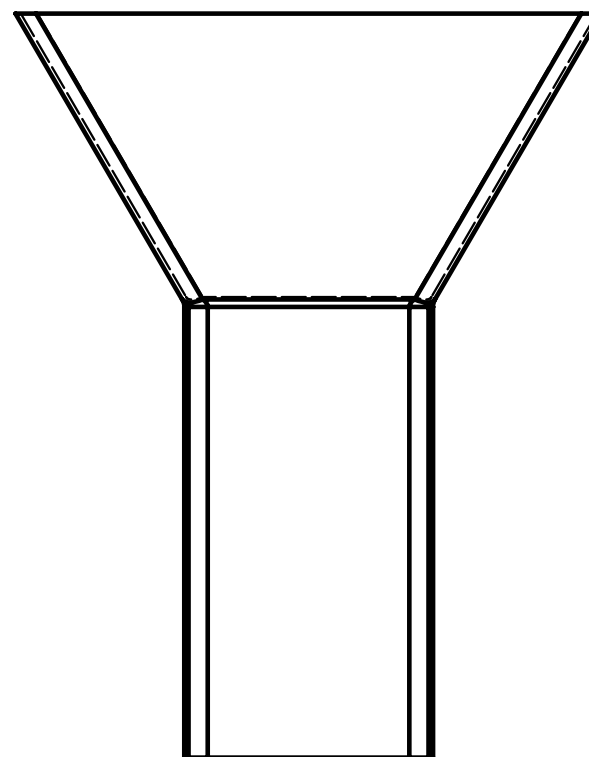
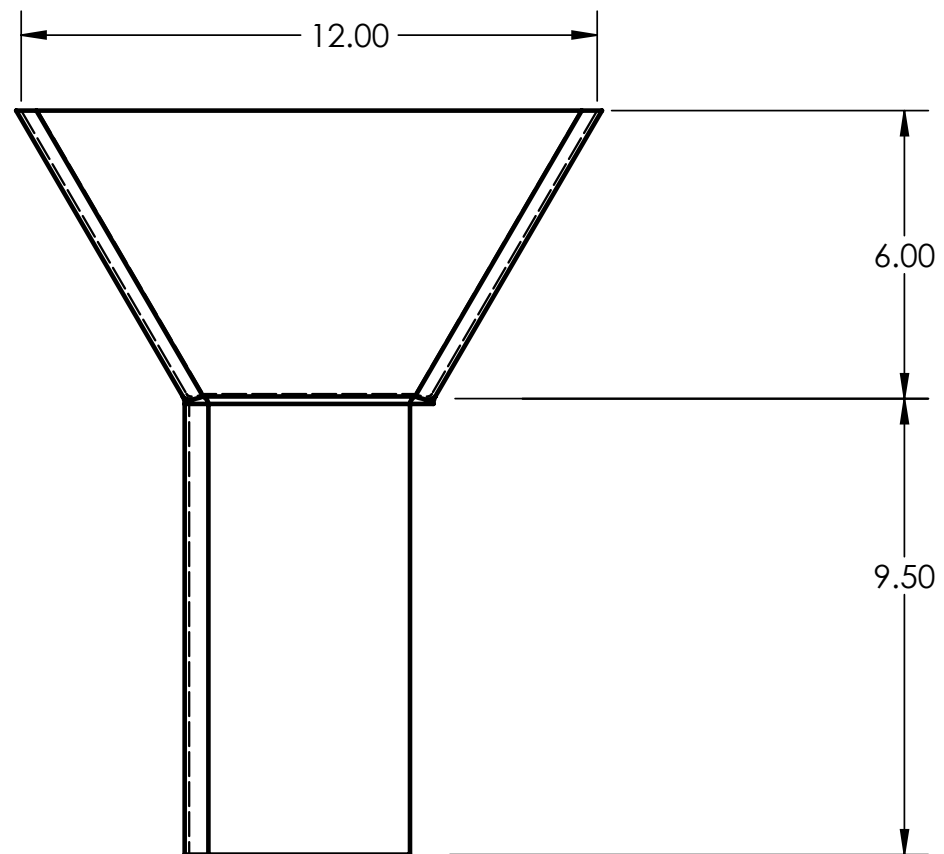
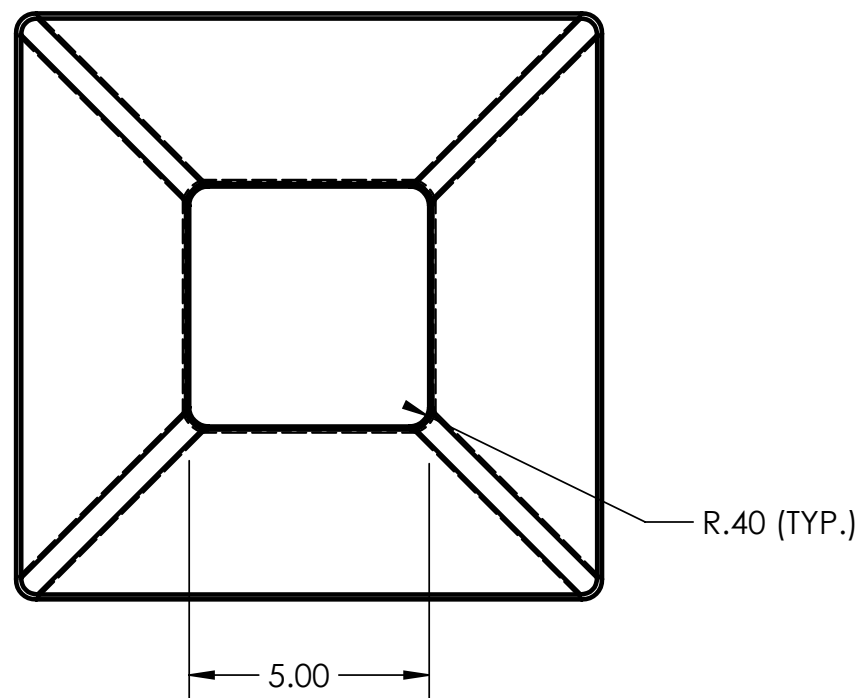

NOTES:

1. MATERIAL SHALL BE 11 GAUGE LOW CARBON STEEL SHEET METAL.
2. ALL DIMENSIONS ARE IN INCHES.
3. ALL TOLERANCES SHALL BE ± 0.01 .
4. THIS DRAWING IS THE PROPERTY OF THE CLOROX COMPANY.



OUTGOING ALIGNMENT A

DR. BY: R.M. FOSTER

SHEET NO.

DATE: 4/24/2021

SCALE: 1:4

1
OF 1

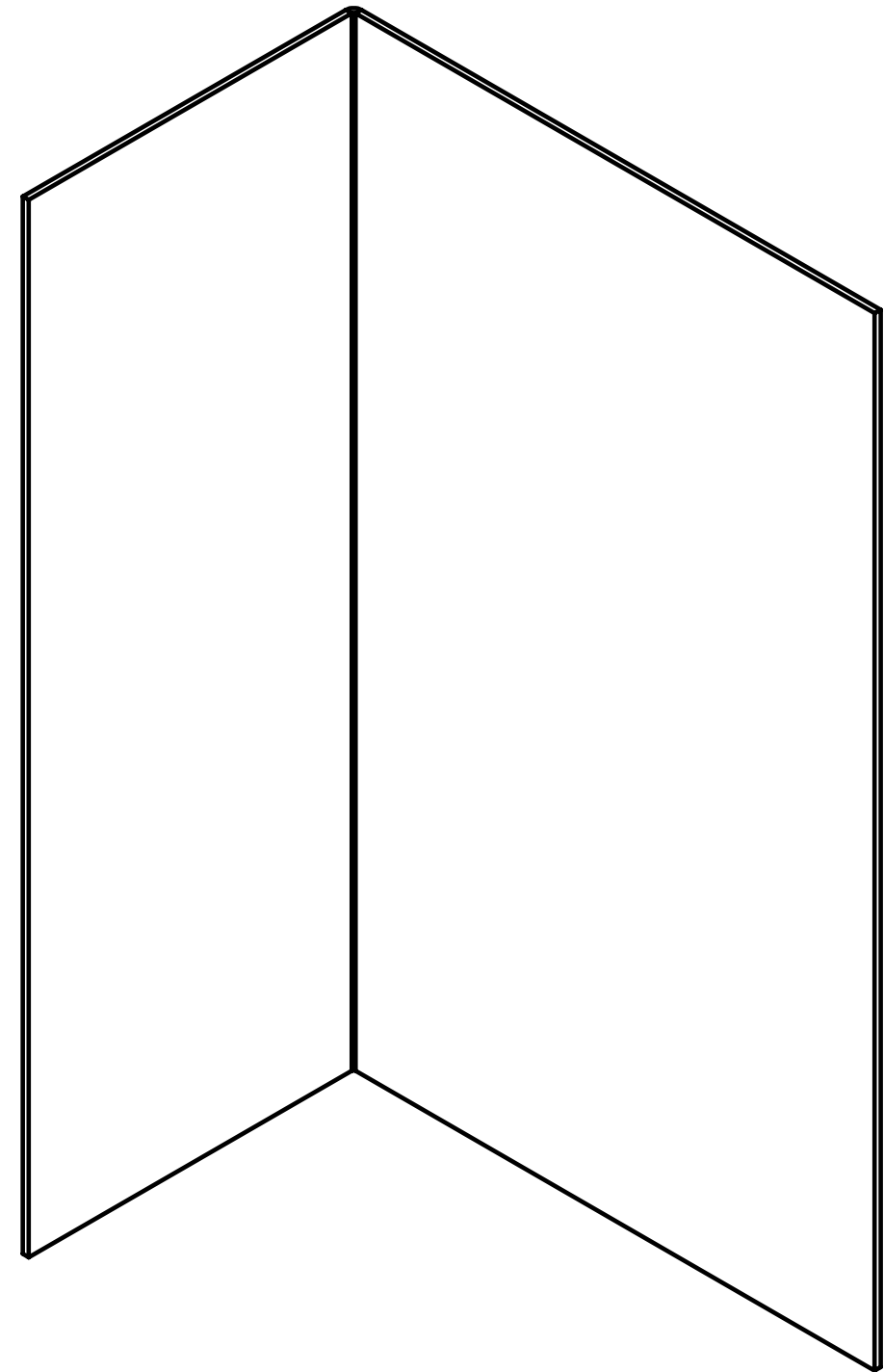
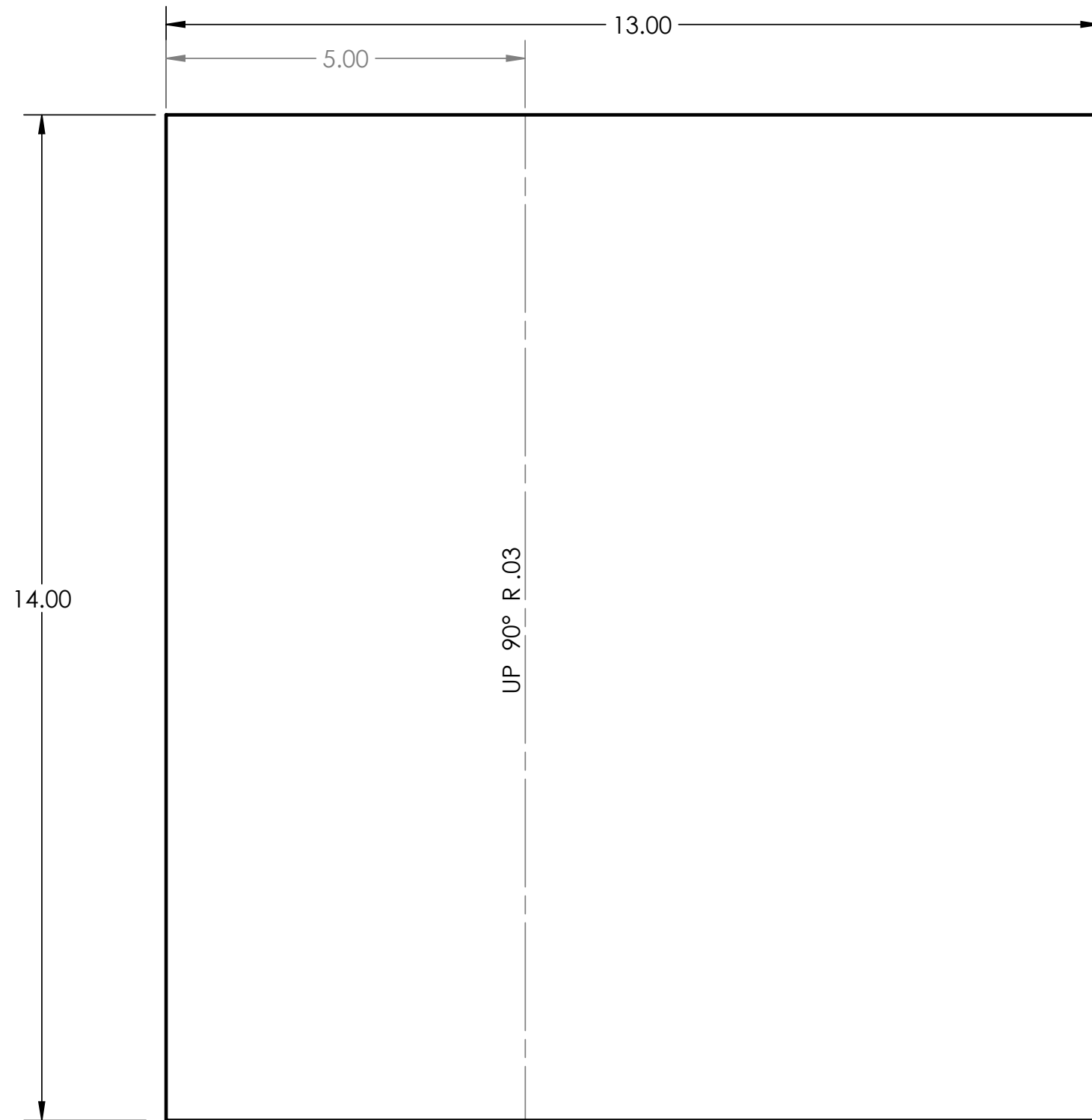

NOTES:

1. MATERIAL SHALL BE 11 GAUGE LOW CARBON STEEL SHEET METAL.
2. ALL DIMENSIONS ARE IN INCHES.
3. ALL TOLERANCES SHALL BE ± 0.01 .
4. THIS DRAWING IS THE PROPERTY OF THE CLOROX COMPANY.



OUTGOING ALIGNMENT B

DR. BY: R.M. FOSTER

SHEET NO.

DATE: 4/24/2021

SCALE: 1:2

1
OF 1